

WLAD 1

WEAPON LASER AIMING DEVICE

USER MANUAL

© 2025 AGM Global Vision, LLC. All rights reserved.

This documentation is subject to change without notice.

No parts of this manual, in whole or in part, may be copied, photocopied, translated, or transmitted by any electronic medium or in machine-readable form without the prior written permission of AGM Global Vision, LLC.

If you have questions that are not covered in this manual, or need service, contact AGM Global Vision customer support for additional information prior to returning a product.

AGM Global Vision, LLC

2407 E Interstate 30, Suite 100

Grand Prairie, TX 75050, USA

Tel. 928.333.4300

support@agmglobalvision.com

www.agmglobalvision.com

EXPORT INFORMATION

Buyer acknowledges that all products supplied by AGM Global Vision, LLC are subject to U.S. export control laws, including, but not limited to, the Export Administration Regulations, the International Economic Emergency Powers Act, and various U.S. embargoes and sanctions. AGM Global Vision products may not be exported, re-exported, or transferred contrary to U.S. export control laws. In particular, AGM Global Vision products may not be exported, re-exported, or transferred to prohibited countries, individuals, organizations, or entities, including but not limited to those individuals and entities listed on the List of Specially Designated Nationals and Blocked Persons administered or maintained by the U.S. Office of Foreign Assets Control ("OFAC"), the various lists maintained by the Bureau of Industry and Security of the Department of Commerce, and the U.S. State Department and Buyer represents and warrants that neither Buyer nor any of its officers, directors, or employees are on such lists. Distribution or resale by Buyer to such countries, individuals, organizations, or entities is expressly prohibited. Buyer has and will maintain a positive process to ensure compliance with this Section.

LIST OF CONTENTS

TITLE	PAGE
Safety Summary	4
SECTION 1. GENERAL INFORMATION	6
1.1 System Description	6
1.2 Standard Components	7
1.3 Key Features	8
SECTION 2. OPERATING INSTRUCTIONS	9
2.1 Installation and Mounting	9
2.2 Operation	13
SECTION 3. MAINTENANCE INSTRUCTIONS	18
3.1 Maintenance	18
3.2 Troubleshooting	19
SECTION 4. WARRANTY INFORMATION	21
4.1 Warranty Information and Registration	21
4.2 Limitation of liability	22
4.3 Product Registration	22
4.4 Obtaining Warranty Service	22
SECTION 5. SPECIFICATIONS	24
5.1 Specifications	24

SAFETY SUMMARY

- Read and follow all instructions
- Read all warnings
- Only use the attachments/accessories specified by the manufacturer
- All service must be provided by the manufacturer

WARNING:

- Always make sure your firearm is unloaded before you place the equipment on the firearm. Reconfirm that the chamber is empty if you stop the procedure then resume later. Safe handling rules should be followed at all times.
- Remember to reinstall the safety lock screw after you have completed operation.
- The light from the equipment's IR laser emitter(s) is invisible to the naked eye. However, the light can be detected by all night vision devices (NVD). To reduce the risk of detection, avoid prolonged activation of the IR laser(s).
- The IR light is more detectable by other NVDs when used in smoke, fog and rain. Avoid prolonged activation of the IR laser(s) in these conditions.
- Take note of the laser safety warning label sticker located near the laser emission aperture. NEVER REMOVE this sticker, which identifies laser wavelengths, laser output power sources, and the safety class of the equipment according to the IEC 60825 1:2014, EN 60825 1:2014+A11:2021, and EN 50689:2021 standard.
- DO NOT leave the WLAD activated when not in active use.
- When adjusting the equipment boresight, beware of reflections from optical surfaces.

CAUTION:

- Do not dismantle the equipment.
- Keep the equipment clean. Protect it from moisture, dramatic temperature changes, and electric shocks.
- DO NOT drop or hit the equipment.
- DO NOT force the equipment controls past their stopping points.
- Do not store the equipment with the battery still installed.
- Thoroughly clean and dry each item before replacing them in the carrying case.

NOTES:

- Remember to zero your weapon prior to installing the WLAD or adjusting the boresight.
- To operate the WLAD IR channel(s), you will need to wear night vision goggles (NVG).

LASER CAUTION:

When any laser equipment is in use, make sure that the device lens is not exposed to the laser beam, or it may burn out. The laser radiation emitted from the device can cause eye injuries, burning of skin or inflammable substances. Before enabling the light supplement function, make sure no human or inflammable substances are in front of the laser lens. Do not place the device where minors can fetch it. According to IEC 60825 1:2014, EN 60825 1:2014+A11:2021, and EN 50689:2021, this laser product is classified as Class 1 laser product and consumer laser product.

Complies with FDA performance standards for laser products except for conformance with IEC 60825-1 Ed. 3., as described in Laser Notice No.56, dated May 8, 2019.

CONSUMER LASER PRODUCT
CLASS 1 LASER PRODUCT
EN 60825-1:2014+A11:2021
IEC 60825-1:2014
EN 50689:2021



1 GENERAL INFORMATION

1.1 SYSTEM DESCRIPTION

The WLAD Weapon Laser Aiming Device is a CLASS 1 laser consisting of a green visible aiming laser, a near-infrared (near-IR) aiming laser, IR illuminator and 300 lm LED illuminator.

The function of the WLAD is to provide an operator with highly collimated aiming lasers for precision aiming and targeting visible in low light conditions and in conjunction with night vision devices for night time applications. The focusable near-IR illuminator floods the area of interest with near-infrared light only visible when used with night vision devices.

The ITEM NO. column in Table 1-2 indicates the number used to identify items in Figures 1-1.

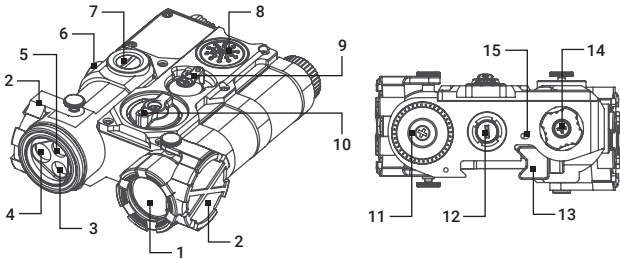

FIGURE 1-1. WLAD

TABLE 1-1. SYSTEM DESCRIPTION

ITEM	DESCRIPTION
1	LED Light
2	Protective Cap
3	IR Laser
4	IR Illuminator
5	Visible Laser
6	Windage Adjustment
7	Elevation Adjustment
8	ON/OFF Button
9	Power Selector
10	Function Selector
11	Battery Compartment
12	Remote Switch Connector
13	Picatinny Rail Mount
14	IR Illuminator Spot Size Adjustment
15	Indicator

1.2 STANDARD COMPONENTS

WLAD 1 standard components are shown in Figure 1-2 and listed in Table 1-2.

The ITEM NO. column indicates the number used to identify items in Figure 1-2.

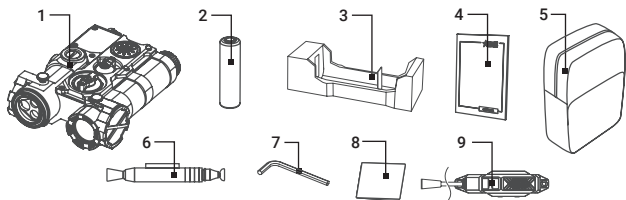

FIGURE 1-2. STANDARD COMPONENTS

TABLE 1-2. STANDARD COMPONENTS

ITEM	DESCRIPTION	QUANTITY
1	Laser Aiming Device	1
2	18650 Battery	1
3	Charger for 18650 Battery	1
4	Manual	1
5	Soft Carrying Case	1
6	Clean Brush	1
7	Hex Key	1
8	Clean Cloth	1
9	Remote Switch	1

1.3 KEY FEATURES

- Rapid active target acquisition
- True night vision compatible mode
- Six function modes
- User selectable constant wave or pulsed modes of flashlight
- 300 Lumen LED flashlight
- Tactical remote switch
- Co-boresighted aiming lasers
- Low base design
- IP68 waterproof
- 3-Year Warranty

2 OPERATING INSTRUCTIONS

2.1 INSTALLATION AND MOUNTING

2.1.1 BATTERY INSTALLATION

The device supports removable 18650 Li-Ion battery. Charge the battery using the included charger. Before first use, charge the battery for more than 4 hours to full capacity.

CAUTION:

Verify that the device is OFF before installing a battery.

Install the battery as follows (refer to Figure 2-1):

1. Unscrew the battery cap (A) and insert the 18650 battery (B), observing the polarity markings on the body of the device.
2. Screw the battery cap back on securely.

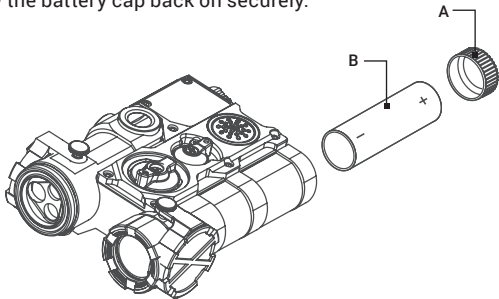

FIGURE 2-1. BATTERY INSTALLATION

2.1.2 MOUNTING THE WLAD ON A PICATINNY/WEAVER RAIL

NOTE:

Remember to zero your weapon prior to installing the WLAD or adjusting the boresight.

WARNING:

Always make sure your firearm is unloaded before you place the equipment on the firearm. Reconfirm that the chamber is empty if you stop the procedure then resume later. Safe handling rules should be followed at all times.

Install the WLAD on a Picatinny/ Weaver rail as follows (refer to Figure 2-2):

1. Loosen the locking mounting knob (refer to Figure 2-2, A). Open the Picatinny rail card slot.
2. Align the guide rail with Picatinny rail card slot, click the device into the guide rail.
3. Lock the mounting knob (refer to Figure 2-2, B).

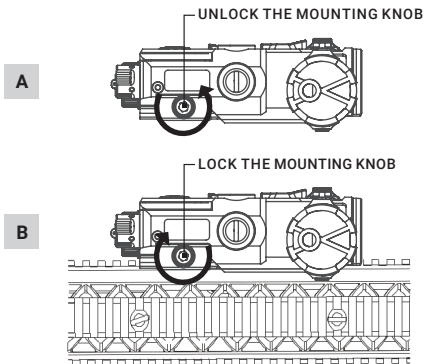

FIGURE 2-2. MOUNT

2.2 OPERATION

2.2.1 SYSTEM CONTROLS

The WLAD controls are shown in Figure 2-3 and defined in Table 2-1. The ITEM NO. column indicates the number used to identify items in Figure 2-3.

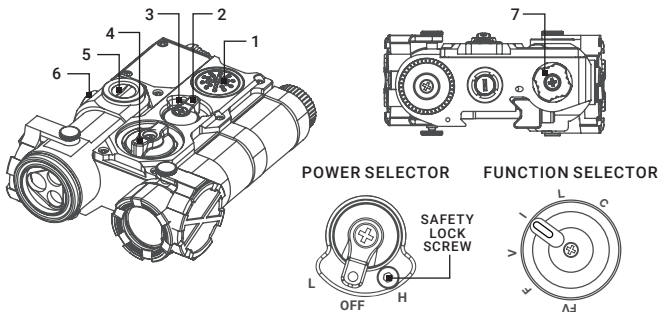

FIGURE 2-3. WLAD CONTROLS

TABLE 2-1. CONTROLS

ITEM	CONTROL	FUNCTION
1	ON/OFF Button	<ul style="list-style-type: none"> • Press and hold the ON/OFF button to activate momentary working mode with the selected function and power. Relief the button to turn off. • Press the ON/OFF button twice to activate the device for continuous operation in the specific selected working mode. Press the button again to turn off. • Strobe Mode: in L/H Power mode, press the ON/OFF button three times to start the LED strobe mode. Press the button again to turn off.

ITEM	CONTROL	FUNCTION
2	Power Selector Switch	<p>Switches between three defined operation modes: "OFF", "L" and "H".</p> <p><u>Modes:</u></p> <p>OFF: Turn Off</p> <p>L: Low Lumen mode</p> <p>H: High Lumen mode</p>
3	Safety Lock Screw	<p>Prevents the mode select switch from being inadvertently turned to high-power position ("H").</p> <p><u>NOTE:</u></p> <p>The "H" position can only be entered when the switch is unlocked. You will need to unscrew the lock screw to operate with high-power level.</p>
4	Function Selector Switch	<p>Switches between the six defined operating modes: "FV", "F", "V", "I", "L" and "C".</p> <p><u>Modes:</u></p> <p>FV: LED+Visible laser sight</p> <p>F: LED</p> <p>V: Visible laser sight</p> <p>I: IR laser sight</p> <p>L: IR Illuminator</p> <p>C: IR laser & IR Illuminator</p>
5	Elevation Adjustment Screw	Adjusts the laser(s) vertical boresight.
6	Windage Adjustment Screw	Adjusts the laser(s) horizontal boresight.
7	IR Illuminator Spot Size Adjustment	Adjusts IR Illuminator spot size.

2.2.2 FUNCTION SELECTOR

The Mode Selection Switch is a rotational knob located on the top side of the WLAD. The mode selection switch allows the operator to choose which what laser or light source will be on when either a remote switch is activated or the integral “ON/OFF” button located on the top of the WLAD is pushed. There are six defined operating modes: “FV”, “F”, “V”, “I”, “L” and “C”.

FV (LED+Visible laser sight): The dual operation of the visible aiming laser and LED flashlight provides rapid target acquisition with the unaided eye in low light environments.

F (LED): The built-in LED light provides bright illumination when you need to see clearly and confidently in low-light conditions.

V (Visible Laser Sight): The visible aiming laser provides rapid target acquisition with the unaided eye.

I (IR laser sight): The near-IR aiming laser provides targeting that is invisible to the unaided eye. NVDs are required to see laser.

L (IR Illuminator): Provides invisible, near-IR illumination to extend range of NVDs and to look into windows, cars, tree-lines, etc.

C (IR laser & IR Illuminator): The dual operation of the near-IR aiming laser and Illuminator permit the target to be flushed out while the aiming laser directs fire.

2.2.3 BUTTON FUNCTION

The WLAD is equipped with an integrated “ON/OFF” button that performs the same function as the remote cable switch and is located on the top of the WLAD. In the event of remote switch damage or failure, the “ON/OFF” button can activate the WLAD.

It should be noted that when the WLAD is positioned on the weapon rail, the stabilizing hand can activate the “ON/OFF” button with the shooter’s thumb.

1. Press and hold the ON/OFF button to activate momentary working mode with the selected function and power. Relief the button to turn off.
2. Press the ON/OFF button twice to activate the device for continuous operation in the specific selected working mode. Press the button again to turn off.
3. Strobe Mode: in L/H Power mode, press the ON/OFF button three times to start the LED strobe mode. Press the button again to turn off.

NOTE:

All the working modes could continuous working in 5 minutes, if there is no more operation, device will enter standby mode.

2.2.4 REMOTE SWITCH

Engage the remote switch by inserting the plug into the mating connector located on the rear back side of the WLAD. Do not try to remove the remote switch by pulling on the cable. Always grip the connector in order to remove.

1. Press the ON/OFF Switch Pad (A) to turn on/off the unit
2. Press and hold the Momentary Switch Pad (B) to tun on the unit, release to tun off.

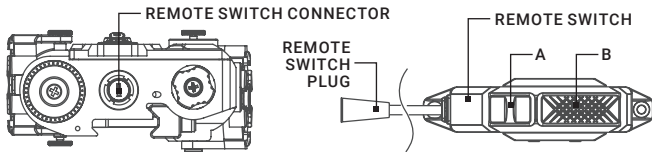

FIGURE 2-4. PREMOTE SWITCH

2.2.5 FOCUSING THE NEAR-IR ILLUMINATOR

The near-IR illuminator on the WLAD can be focused manually by turning the knurled knob on the rear side of device. The beam divergence can be adjusted approximates from 1 mRad to 108 mRad.

2.2.6 INDICATION

The WLAD has a bi-color LED indicator on the rear side that shows the functional status of the system.

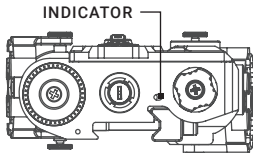

FIGURE 2-5. INDICATOR

1. Blue Indicator indicates the IR and IR light function is activated.
2. Green Indicator indicates the visible laser and LED light function is activated.
3. Green/Blue flashing light warn that the battery is low.

NOTE:

The indicator will remain on in standby mode.

2.2.7 OPERATING PROCEDURE

To operate the WLAD:

1. Ensure that the Power switch is positioned to “OFF” and charged 18650 battery is installed.
2. Connect the remote switch.
3. Remove the cap(s) from the output aperture(s).
4. Turn the Function Selector switch to the required position.
5. Turn the Power Selector switch to the required position. If you are operating the device using high-power levels, use a 2mm hex key to unscrew the safety lock.
5. Activate WLAD (refer to 2.2.3 or 2.2.4).
6. To align the weapon barrel, center the aiming dot on the target.
7. When using IR illuminator, adjust the beam divergence.

WARNING:

DO NOT leave the WLAD activated when it’s not in use.

WARNING:

The IR light from the IR laser and IR illuminator is invisible to the naked eye. However, the light can be detected by all night vision devices. To reduce the risk of detection, avoid prolonged activation of the IR source.

NOTE:

To switch the activated equipment to another operation mode, turn the switch to the desired position and reactivate the device by pushing ON button or remote switch.

2.2.8 BORESIGHT ADJUSTMENT PROCEDURE

NOTES:

- Before adjusting the WLAD boresight for the first time, fire approximately 10 shots from the weapon with the device installed, in order to stabilize the adjustment mechanisms under applied shocks.
- When adjusting the equipment boresight, beware of reflections from optical surfaces.
- Remember that the adjustment screws adjust the boresight of both visible and IR lasers concurrently.
- When turning the screws, adjustment mechanisms click in increments corresponding to the minimum boresight correction value 0.25 mils (2.5cm at a distance of 100m).
- Elevation and windage adjustment ranges are covered in approximately 4 turns of the screws.

To adjust the boresight:

1. Locate a target at the fire adjustment range (25m).
2. Take aim at the center of the target using the weapon's iron sight; secure the weapon in the aiming rest.
3. Remove the cap from the output aperture of the aiming laser.
4. Turn the Function Selector Switch to the required position (V), and activate the WLAD (press ON/OFF button twice).
5. Adjust the laser to co-align with the boresighted iron sight.
6. Fire a series of three (3) shots in order to check grouping.
7. Shift range to 100m and recheck co-alignment of visible laser against boresighted iron sights. Adjust as needed.
8. Fire a series of three (3) shots in order to check grouping.
9. Work out the values of the elevation and windage corrections required to compensate for the measured deviation of the mean point of impact (MPI) from the center of the target. The correction value of 0.25 mils (2.5 cm at a distance of 100 m) corresponds to one click of the adjustment mechanisms.
10. Adjust the equipment boresight by turning the adjustment screws and counting out a definite number of clicks.

NOTE:

To shift the MPI to the right, turn the windage adjustment screw CCW. To shift the MPI to the left, turn the screw CW.

To shift the MPI down, turn the elevation adjustment screw CW. To shift the MPI up, turn the screw CCW.

10. To check the equipment boresight, use the laser dot to take aim at the center of the target and fire a series of shots.
11. After completing the boresight adjustment procedure, turn the device off and replace the cap on the laser output aperture.

2.2.9 WLAD SHUT-DOWN

To shut down the WLAD:

1. Turn the switch to OFF.
2. Replace the cap(s) on the output aperture(s).
3. Remove the equipment from the weapon rail.
4. Reinstall the safety lock screw (if removed).

WARNING:

Remember to reinstall the safety lock screw after you have completed any high-output operation.

5. Remove the battery.

CAUTION:

Do not store the equipment with the battery still installed.

6. Store the WLAD and all accessories in the carrying case.

3 MAINTENANCE INSTRUCTIONS

3.1 MAINTENANCE

CAUTION:

The WLAD is a precision electro-optical instrument and must be handled carefully at all times to prevent damage.

CAUTION:

DO NOT dismantle the equipment.

3.1.1 PREVENTIVE MAINTENANCE

After each use, clean the WLAD by flushing with fresh water and wiping away excess with a soft, dry cloth. Fresh water cleaning should be conducted on the WLAD after each use and especially after exposure to salt water, chemicals, and other foreign matter.

Use the supplied treated lens cloth to gently and carefully wipe down the laser aiming and illumination windows. If not available, then use a soft cloth dampened with clean water, alcohol, or general purpose window cleaner to gently remove any debris or foreign matter taking special care not to scratch the laser windows.

Prior to use in operations where immersion in water is required, inspect the o-ring seals in the battery cap to make sure that it is free of sand, dirt, or other foreign particles. Thoroughly clean the o-ring, battery cap, and the back of the battery compartment where the o-ring seals against the main body. If the o-ring becomes nicked or cut or is observed to be dried out, then the o-ring should be replaced. If the battery cap is bent or scratched/scarred in the o-ring seat area, then it should be replaced. Periodically lubricate all o-rings with fluorinated grease.

Perform an inspection after each use paying careful attention to rubber caps. Replace missing or damaged covers. Also check the basic kit inventory to make sure that no parts or components are damaged or missing. Inspect the buttons and switches for cracks and wear before

and after each mission. Verify that all parts are intact and repair or replace any damaged or missing components.

Check labels to make sure that they are not missing or illegible due to use and routine damage.

All user repair parts can be installed at the unit level. No special tools or equipment are required to service and maintain the WLAD mission-ready status.

3.1.2 BORESIGHT TESTING

Perform boresight testing:

- When the WLAD is mounted to a weapon for the first time;
- After repair of the WLAD or weapon;
- As the need arises (in case of systematic inaccuracy or missing the target).

Test the WLAD boresight as per Part 2.2.8.

3.2 TROUBLESHOOTING

The purpose of troubleshooting is to identify the most commonly occurring equipment malfunctions, their probable causes, and the corrective actions required to fix them.

Table 3-1 lists common malfunctions that may occur during the operation or maintenance of the WLAD. Perform the tests, inspections, and corrective actions in the order listed in the table.

This table cannot list all of the malfunctions that may occur with your WLAD, or all of the tests and corrective actions that may be necessary. If you experience an equipment malfunction that is not listed, or is not fixed by the corrective actions listed in the table, please contact the Customer Support.

TABLE 3-1. TROUBLESHOOTING

MALFUNCTION	PROBABLE CAUSE/ TEST/ INSPECTION	CORRECTIVE ACTION
WLAD fails to activate (no aiming dot, no illumination).	Check to see if lens caps are removed.	Remove lens caps.
	Check to see if laser beam windows are	Clean laser windows.
	Battery is dead, missing or improperly installed.	Replace or charge the battery or install it correctly.
	Battery contact surfaces or contact springs are dirty or corroded.	Clean as per Part 3.1.1.
	Check mode selection settings.	Verify settings and reset.
	Laser diode is faulty.	Please contact the Customer Support.
Aiming or Illumination beams are weak or poor quality.	Check to see if laser beam windows are obscured with mud, dirt or foreign debris.	Clean laser windows.
	Check to see if lenses are scratched or pitted.	Please contact the Customer Support.
Boresight adjustment screws do not adjust for aiming dot position.	Adjustment mechanisms are dirty.	Clean as per Part 3.1.1.
	Adjustment mechanisms are faulty.	Please contact the Customer Support.
Remote switch does not work.	Check to see that remote switch is well-seated in the socket.	Reconnect the plug.
	Check remote switch socket for mud and dirt.	Clean as per Part 3.1.1.
	Remote control unit is damaged.	Please contact Customer Support.
Hindered rotation of the battery cap.	Dirty cap thread.	Clean the thread.
	Damaged cap thread.	Please contact the Customer Support.

4 WARRANTY INFORMATION

4.1 WARRANTY INFORMATION

This product is guaranteed to be free from manufacturing defects in material and workmanship under normal use for a period of three (3) years from the date of purchase. In the event that a defect covered by the warranty below occurs during the applicable period stated above, AGM Global Vision, at its discretion, will either repair or replace the product; such action on the part of AGM Global Vision shall be the full extent of AGM Global Vision's liability, and the Customer's sole and exclusive repairation. This warranty does not cover a product if it has been (a) used in ways other than its normal and customary manner; (b) subjected to misuse; (-) subjected to alterations, modifications or repairs by the Customer or by any party other than AGM Global Vision without prior written consent of AGM Global Vision; (d) is the result of a special order or categorized as "close-out" merchandise or merchandise sold "as-is" by either AGM Global Vision or the AGM Global Vision dealer; or (e) merchandise that has been discontinued by the manufacturer and either parts or replacement units are not available due to reasons beyond the control of AGM Global Vision. AGM Global Vision shall not be responsible for any defects or damage that in AGM Global Vision's view are a result from the mishandling, abuse, misuse, improper storage or improper operation of the device, including use in conjunction with equipment that is electrically or mechanically incompatible with, or of inferior quality to, the product, as well as failure to maintain the environmental conditions specified by the manufacturer. This warranty is extended only to the original purchaser. Any breach of this warranty shall be enforced unless the customer notifies AGM Global Vision at the address noted below within the applicable warranty period. The customer understands and agrees that except for the foregoing warranty, no other warranties written or oral, statutory, expressed or implied, including any implied warranty of merchantability or fitness for a particular purpose, shall apply to the product. All such implied warranties are hereby and expressly disclaimed.

4.2 LIMITATION OF LIABILITY

AGM Global Vision will not be liable for any claims, actions, suits, proceedings, costs, expenses, damages, or liabilities arising out of the use of this product. Operation and use of the product are the sole responsibility of the Customer. AGM Global Vision's sole undertaking is limited to providing the products and services outlined herein in accordance with the terms and conditions of this Agreement. The provision of products sold and services performed by AGM Global Vision to the Customer shall not be interpreted, construed, or regarded, either expressly or implied, as being for the benefit of or creating any obligation toward any third party of legal entity outside AGM Global Vision and the Customer; AGM Global Vision's obligations under this Agreement extend solely to the Customer. AGM Global Vision's liability hereunder for damages, regardless of the form or action, shall not exceed the fees or other charges paid to AGM Global Vision by the customer or customer's dealer. AGM Global Vision shall not, in any event, be liable for special, indirect, incidental, or consequential damages, including, but not limited to, lost income, lost revenue, or lost profit, whether such damages were foreseeable or not at the time of purchase, and whether or not such damages arise out of a breach of warranty, a breach of agreement, negligence, strict liability, or any other theory of liability.

4.3 PRODUCT REGISTRATION

In order to validate the warranty on your product, the customer must complete and submit AGM Global Vision PRODUCT REGISTRATION FORM on our website (www.agmglobalvision.com/customer-support).

4.4 OBTAINING WARRANTY SERVICE

To obtain warranty service on your unit, the End-user (Customer) must notify the AGM Global Vision service department via e-mail. Send any requests to support@agmglobalvision.com to receive a Return Merchandise Authorization number (RMA). When returning any device, please take the product to your retailer, or send the product, postage paid and with a copy of your sales receipt, to AGM Global Vision's service center at the address listed above. All merchandise must be fully insured with the correct postage; AGM Global Vision will not be responsible for improper postage or merchandise that becomes lost or damaged during

shipment. When sending product back, please clearly write the RMA# on the outside of the shipping box. Please include a letter that indicates your RMA#, the Customer's Name, a Return Address, reason for the return, contact information (valid telephone numbers and/or an e-mail address), and proof of purchase that will help us to establish the valid start date of the warranty. Product merchandise returns that do not have an RMA# listed may be refused, or a significant delay in processing may occur. Estimated Warranty service time is 10-20 business days. The End-user/Customer is responsible for postage to AGM Global Vision for warranty service. AGM Global Vision will cover return postage/shipping after warranty repair to the End-user/Customer only if the product is covered by the aforementioned warranty. AGM Global Vision will return the product after warranty service by domestic UPS Ground service and/or domestic mail. Should any other requested, required, or international shipping methods be necessary, the postage/shipping fee will be the responsibility of the End-user/Customer.

For service, repair or replacement, please contact:

AGM Global Vision, LLC

2407 E Interstate 30, Suite 100

Grand Prairie, TX 75050, USA

Tel. 928.333.4300

support@agmglobalvision.com

www.agmglobalvision.com

5 SPECIFICATIONS

5.1 SPECIFICATIONS

The following tables provide information pertaining to the operational, optical, electrical, mechanical, and environmental characteristics of the WLAD 1.

TABLE 5-1. SPECIFICATIONS

ITEM	IR LASER	VISIBLE LASER	IR ILLUMINATOR
Class	Class 1		
Output Power	<0.2 mW	<1 mW	<0.7 mW
Operating Distance	> 200 m	> 25 m (in direct sunlight)	> 100 m
Divergence	0.5+0.3 mrad	0.5+0.3 mrad	1-100 mrad
Wavelength	850±15 nm	520±15 nm	830±15 nm
W/E Adjustment	0.25 mil		
Retention after 1,000 Shots	1 mrad		
Battery Type	One 18650 Li-Ion rechargeable battery (3.7V)		
Operating Temperature	-20°C to 50°C (-4°F to 131°F)		
Water and Dust Proof	IP68		
Shockproof	1,200 G		
Color	Black (WLAD-1B) / Tan (WLAD-1T)		
Dimensions	298 g (10.5 oz)		
Weight	113 × 77 × 42 mm (4.3 × 3.0 × 1.5 in)		



AGM Global Vision, LLC

MAIN OFFICE

2407 E Interstate 30,
Suite 100

Grand Prairie, TX 75050

USA

Tel. +1.928.333.4300

info@agmglobalvision.com

www.agmglobalvision.com

EUROPEAN OFFICE

#6 Andrey Lyapchev Blvd

Sofia, P.C. 1756

Bulgaria

Tel. +35.988.560.0326

info@agmglobalvision.eu

www.agmglobalvision.eu

AGMglobalvision.com