

WOLF-14

NIGHT VISION MONOCULAR

USER MANUAL

© 2025 AGM Global Vision, LLC. All rights reserved.

This documentation is subject to change without notice.

No parts of this manual, in whole or in part, may be copied, photocopied, translated, or transmitted by any electronic medium or in machine-readable form without the prior written permission of AGM Global Vision, LLC.

If you have questions that are not covered in this manual, or need service, contact AGM Global Vision customer support for additional information prior to returning a product.

AGM Global Vision, LLC

2407 E Interstate 30, Suite 100

Grand Prairie, TX 75050

Tel. 928.333.4300

support@agmglobalvision.com

www.agmglobalvision.com

EXPORT INFORMATION

Buyer acknowledges that all products supplied by AGM Global Vision, LLC are subject to U.S. export control laws, including, but not limited to, the Export Administration Regulations, the International Traffic in Arms Regulations, the International Economic Emergency Powers Act, and various U.S. embargoes and sanctions. AGM Global Vision products may not be exported, re-exported, or transferred contrary to U.S. export control laws. In particular, AGM Global Vision products may not be exported, re-exported, or transferred to prohibited countries, individuals, organizations, or entities, including but not limited to those individuals and entities listed on the List of Specially Designated Nationals and Blocked Persons administered or maintained by the U.S. Office of Foreign Assets Control ("OFAC"), the various lists maintained by the Bureau of Industry and Security of the Department of Commerce, and the U.S. State Department and Buyer represents and warrants that neither Buyer nor any of its officers, directors, or employees are on such lists. Distribution or resale by Buyer to such countries, individuals, organizations, or entities is expressly prohibited. Buyer has and will maintain a positive process to ensure compliance with this Section.

LIST OF CONTENTS

TITLE	PAGE
Safety Summary	4
SECTION 1. GENERAL INFORMATION	6
1.1 System Description	6
1.2 Key Features	7
1.3 Standard Components	7
SECTION 2. OPERATING INSTRUCTIONS	8
2.1 Installation and Mounting	8
2.2 Controls	9
2.3 Operating Procedures	10
SECTION 3. MAINTENANCE INSTRUCTIONS	11
3.1 Cleaning Procedures	11
3.2 Troubleshooting	11
3.3 Preparation for Extended Storage	12
SECTION 4. WARRANTY INFORMATION	13
4.1 Warranty Information and Registration	13
SECTION 5. SPECIFICATIONS	15
5.1 Specifications	15

SAFETY SUMMARY

- Read and follow all instructions
- Read all warnings
- Only use the attachments/accessories specified by the manufacturer
- All service must be provided by the manufacturer

WARNING:

This product contains natural rubber latex, which may cause potentially fatal allergic reactions! If you are allergic to latex, it is important that you strictly avoid exposure to products that contain it.

WARNING:

The intensifier's phosphor screen contains toxic materials.

Please note:

- If the intensifier tube breaks, be extremely careful to avoid inhaling the phosphor screen material. **DO NOT** allow the material to come in contact with your mouth, eyes, or any open wounds on the skin.
- If the phosphor screen material comes in contact with your skin, wash it off immediately with soap and water.
- If you inhale or swallow any phosphor screen material, drink a lot of water, induce vomiting, and seek medical attention as soon as possible.

WARNINGS:

- When used in total darkness, the light from the unit's infrared (IR) illuminator is invisible to the naked eye. **However, the light can be detected by other Night Vision Devices (NVD).**
- To reduce the risk of detection by another NVD, avoid prolonged use of the IR illuminator.
- Light from the IR illuminator is more easily detected by other NVDs when used in fog, smoke, and rain. Avoid prolonged use of the IR illuminator in these conditions.
- Do not use contaminated eyecups. If it is contaminated, it must be replaced.

CAUTIONS:

The Wolf-14 night vision monocular is a precision electro-optical instrument and requires careful handling. Please follow the below instructions for safe use:

- Do not disassemble the unit.
- Keep the unit clean; protect it from moisture, sudden temperature drops and shocks.
- Be careful not to touch the glass surfaces. If you leave finger-prints on, or contaminate the glass surfaces, use only clean and soft materials to clean it.
- Protect the unit from excessive lighting. Do not turn the monocular on in daylight with the front lens cap off. Do not point the monocular at the bright light source (a fire, car headlights, lanterns, street lamps, room lights, etc.).
- Do not test the device in daylight conditions even with the daylight filter/lens cap on for more than ten (10) minutes.
- Do not leave the unit in on position during stops in operation.
- Remove the battery from the unit when it will be stored for over 3 days. Failure to do so may damage the unit.

EQUIPMENT LIMITATIONS

To avoid injuries and equipment damage from using the Wolf-14, carefully read and consider the following equipment limitations.

- The built-in IR illuminator is meant to provide additional illumination when needed, while viewing scenes at close distances (up to 3 meters).
- The equipment requires some night light (moonlight, starlight, etc.) to operate. The level of equipment performance depends upon the level of light.
- Night light reduces by passing through the clouds, while operating under trees, under the shadows of houses, etc.
- The device is less effective when peering into shadows and other darkened areas.
- The device is less effective in viewing through rain, fog, sleet, snow or smoke.
- The equipment will not “see” through dense smoke.
- Its protection system cuts off the image intensifier when ambient light level continues to exceed of 40 lux for 10 seconds or more.
- Under starlight conditions low contrast environments (such as snow-covered territory, sandy deserts, large bodies of water or grassy hills) degrade visibility thereby disguising or masking changes in terrain.
- Under too low-light conditions the monocular loses some of the resolution it has under full moon conditions.

1 GENERAL INFORMATION

1.1 SYSTEM DESCRIPTION

The Wolf-14 can be used as a handheld, head-mounted, or helmet-mounted night vision system to enable mobility, driving, use of weapons, short-range surveillance, map reading, vehicle maintenance, and the administration of first aid during nighttime operation.

The Wolf-14 uses advanced, multi-coated optics and a tough, compact, ergonomic housing. The Wolf-14 can be used as a goggle system, or stowed out of the line of sight without the need to completely remove it. This device operates with a single operating knob. When used in conjunction with a head or helmet mount, it also includes features such as the flip-up turn off function. There is also an integrated infrared illuminator for reading maps and short distance observation.

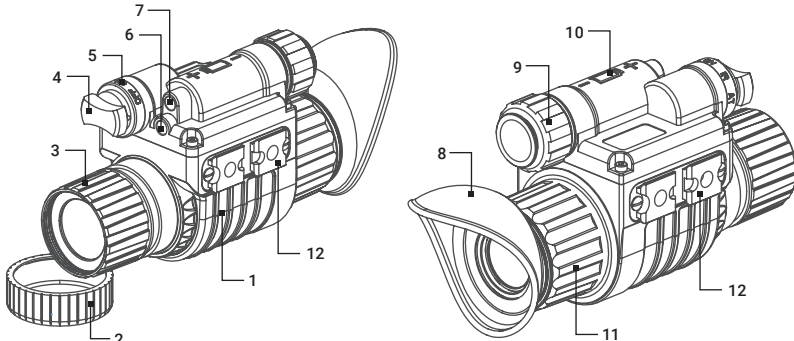

FIGURE 1-1. WOLF-14 MAIN PARTS

TABLE 1-1. WOLF-14 SYSTEM DESCRIPTION

ITEM	DESCRIPTION
1	Body
2	Lens Cap
3	Focus Ring
4	Operating Mode Switch
5	Operation Mode Marking
6	Environmental Light Sensor

ITEM	DESCRIPTION
7	Built-In IR Illuminator
8	Eyecup
9	Battery Cap
10	Battery Polarity Marking
11	Diopter Adjustment Ring
12	Mounting Mini-Rail

1.2 KEY FEATURES

- Compact, rugged design
- Head or helmet mountable for hands-free use
- Bright light cut-off
- Ergonomic, simple, easy to operate controls
- Utilizes single CR123A Lithium battery
- Built-in infrared illuminator
- Limited 3-year warranty

1.3 STANDARD COMPONENTS

The standard components of the Wolf-14 are shown in Figure 1-2 and listed in Table 1-2. The ITEM NO. column indicates the number used to identify items in Figure 1-2.

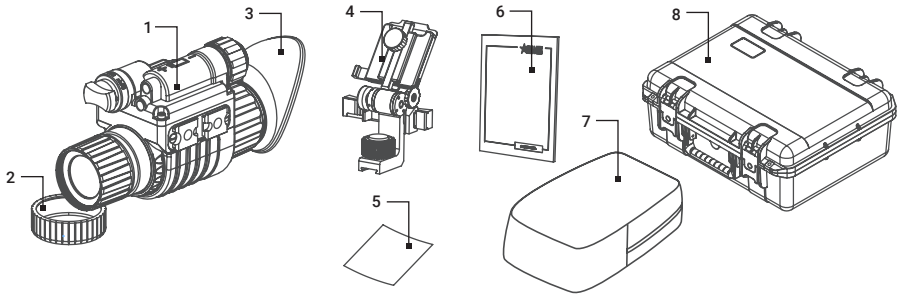

FIGURE 1-2. WOLF-14 STANDARD COMPONENTS

TABLE 1-2. WOLF-14 STANDARD COMPONENTS

ITEM	DESCRIPTION	QUANTITY
1	Monocular with 1x Objective Lens	1
2	Lens Cap	1
3	Eyecup	1
4	Helmet Mount	1
5	Lens Paper	1
6	User Manual	1
7	Soft Carrying Case	1
8	Hard Case for Storage/Transportation	1

2 OPERATING INSTRUCTIONS

2.1. INSTALLATION AND MOUNTING

CAUTION:

To protect the intensifier tube when the sight is not in use or when it is being operated in daylight, keep the protective lens cap secure fitted over the lens.

2.1.1 BATTERY INSTALLATION

The Wolf-14 operates on a single CR123A battery.

Install the battery as follows (refer to Figure 2-1):

1. Unscrew the battery cap (A) and insert the CR123A battery (B), observing the polarity markings on the body of the device (C).
2. Screw the battery cap back securely.

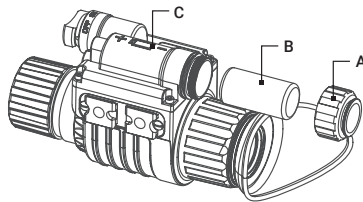

FIGURE 2-1. BATTERY INSTALLATION

2.1.2 MOUNTING THE WOLF-14 TO A HELMET MOUNT

An flip-up helmet mount can be used to attach the Wolf-14 to a helmet or a head-gear.

Mount the Wolf-14 to a helmet mount as follows (refer to Figure 2-2):

1. Loosen the screw (A). With the button (B) pushed down, insert the Wolf-14 rail into the guide (C) of the helmet mount bracket. Tighten the screw (A).
2. Push the button (D) and move the unit along the slide-rail (E) until the most comfortable position is reached.
3. Adjust the mount for comfortable using. Loosen the screw (A) and move the unit along the guide (C) for eye relief adjustment. Loosen the screw (F) and move the unit along vertical slide-rail until the most comfortable vertical position is reached.
4. To remove the Wolf-14 from the field of view and flip it up, push the button (G) and lift the unit up until it reaches the top fixed position. The unit will automatically turn off when it reaches this position.

5. Push the same button (G) to lower the Wolf-14 into the proper viewing position. The device will turn on automatically to continue the session.

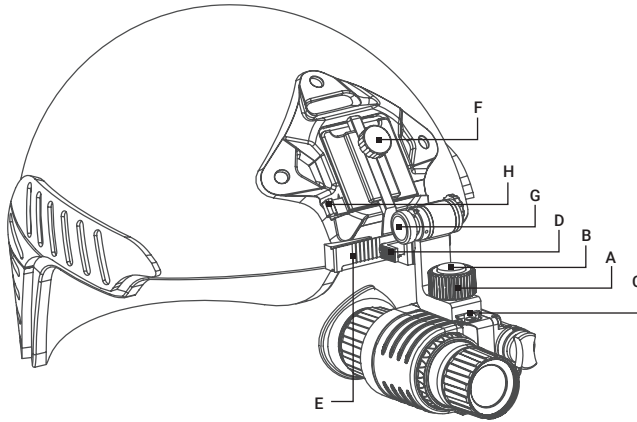

FIGURE 2-2. MOUNTING THE WOLF-14 TO A HELMET MOUNT

To readjust the Wolf-14 for the other eye, reverse its positioning and reinstall it on the helmet mount bracket. Use the second unit rail located on the opposite side of the unit. Push the button (D) and move the unit along the slide-rail (E) until the most comfortable position is reached.

To remove the Wolf-14 from the helmet mount, loosen the screw (A), push down on the button (B), and slide the unit out of the guide (C). To remove the Head/Helmet Mount from the helmet shroud, push the button (H).

2.2 CONTROLS

2.2.1 OPERATING SWITCH

The device is turned off when the switch is in the “OFF” position. Turn on the device and select the operating mode by rotation the switch.

The ON position of the switch corresponds to the operation mode when only the image intensifier tube works (IR illumination is off).

The IR position corresponds to operation mode when the device works with the built-in IR illuminator. This mode is used when there is insufficient natural light.

The AT position corresponds to automatic operation mode. The automatic mode uses the environmental light sensor. It can detect environmental illuminance in real time and works with reference to control system. Under extremely low lighting or in full dark environment, the system will automatically turn on built-in infrared auxiliary lighting, and when the environmental illumination increases, the system will automatically turn off the IR illumination.

When the ambient illumination reaches 40-100 Lux, the image intensifier tube will automatically shut down to protect the photosensitive core components from damage by strong light.

2.2.2 DIOPTRER ADJUSTMENT RING

Adjusting the diopter allows the user to control the sharpness of the image. While looking through the eyepiece, rotate the diopter adjustment ring until the image is clear.

2.2.3 FOCUS RING

Bring targets into focus by rotating the objective focus ring until the target appears clear and sharp (CCW for far away objects, CW for close objects).

2.3 OPERATING PROCEDURES

2.3.1 OPERATING PROCEDURES

1. Verify that the battery is installed properly.

NOTE:

Only operate the monocular in dark environments. If it necessary to operate the device in daylight, always cover the objective lens with lens cap. The pinhole at the centre of the lens cap will allow the user to check operational capabilities in daylight conditions.

2. Remove the lens cap.

3. Turn the monocular on. After a slight delay, a green or white glow will appear in the eyepiece.

4. Adjust the diopter by rotating the adjustment ring.

5. Adjust the focus. Rotate the focus ring until the image is clear and sharp.

NOTE:

If the bright light cut-off feature turns the device off, it will automatically turn back on once the light in the surrounding environment decreases to an acceptable level, or the device is remitted to a darker area.

2.3.2 OPERATING UNDER CHANGING LIGHT CONDITIONS

If the ambient light level exceeds 40-100 Lux for more than 10 seconds, the automatic protective system will shut off the intensifier tube. If an operation must be carried out in changing light conditions, the user can shut down the protective system manually by closing the photoreceiver.

CAUTION:

DO NOT forget to open the photoreceiver after completing your mission.

2.3.3 WOLF-14 SHUT-DOWN

1. Turn the function switch to the OFF position. The green glow of the viewing area will fade to black.

2. Secure the lens cap over the objective lens.

3. If necessary, remove the unit from the rail or mount.

4. Unscrew the battery cap and remove the battery. Replace the battery cap. Do not store the unit with the battery installed.

5. Store the unit and all accessories in the case.

3 MAINTENANCE INSTRUCTIONS

3.1 CLEANING PROCEDURES

Wipe the housing with a damp cloth as needed.

CAUTION:

Do not use abrasives or solvents to clean the housing, lens, or the display window of the device. Do not use ammonia-based cleaning products to clean the lens. Doing so may damage the anti-reflective coating of the lens. Doing so may damage the anti-reflective coating on the lens.

The Wolf-14 lens is designed for the harsh outdoor environment and has a coating for durability and anti-reflection, but it may require occasional cleaning. Avoid scratching the lens and/ or leaving fingerprints on the lens. Optics can be damaged by improper cleaning. Clean the lens according to the instructions below.

Do not use abrasive materials, such as paper towels or scrub brushes to clean lens, as this can scratch or otherwise damage the lens. Only clean when there is visible contamination on the surface.

Preferred Method for Cleaning the Lens

Materials:

- Optical-grade cloth
- Pure water (deionized or other)
- Isopropyl alcohol (IPA)

Saturate a piece of the lens cloth with water and drape it over the lens. Let the surface tension of the water pull the cloth onto the lens surface. Drag the cloth across the lens surface. Repeat several times with different pieces of cloth.

Repeat the same steps using isopropyl alcohol instead of water. Drag the final piece of tissue over the lens several times to prevent pooling, which may leave a residue behind.

3.2 TROUBLESHOOTING

Table 3-1 lists the most common malfunctions that may occur with your device. Perform the tests, inspections, and corrective actions in accordance with the instructions given in the table.

This table does not list all the malfunctions that may occur with your device, or all of the tests, inspections, and corrective actions that may be necessary to fix them. If the equipment malfunction is not corrected by the suggested actions, or a problem occurs that is not listed in this table, please contact AGM Global Vision's Customer Support center or your retailer.

TABLE 3-1. TROUBLESHOOTING

MALFUNCTION	PROBABLE CAUSE/ TEST/ INSPECTION	CORRECTIVE ACTION
Monocular fails to activate.	Battery is dead, missing or improperly installed.	Replace the battery or reinstall it correctly.
	Battery contact surfaces or contact springs are dirty or corroded.	Clean the contact surfaces with a pencil eraser and/ or alcohol and cotton swabs.
	Defective image intensifier.	Please contact Customer Support.
IR illuminator fails to activate.	Turn the IR illuminator on in a dark area. Visually estimate whether or not the observed scene is illuminated.	If the IR illuminator fails to activate, please contact Customer Support.
Poor image quality.	Check objective lens or eyepiece focus.	Refocus the lens.
	Check for fogging or dirt on the lens.	Clean the lens as detailed in Part 3.1. If image quality is still poor, please contact Customer Support.
	Damaged optical components.	Please contact Customer Support
Light is visible around the eyecup.	Check the exit pupil distance value.	Readjust for proper eye-relief distance.
	Check the eyecup resilience.	If the eyecup is defective, please contact Customer Support.
Eyepiece ring cannot be moved.	Check to see if the eyepiece ring is bent or broken.	If damaged, please contact Customer Support.

3.3 PREPARATION FOR EXTENDED STORAGE

1. Unscrew the battery cap and remove the battery from the monocular.
2. Inspect the battery compartment for corrosion or moisture. Clean and dry if necessary.
3. Replace the battery cap.
4. Remove all optional equipment, if installed.
5. Ensure that the monocular, accessories and case are free of dirt, dust, and moisture.
6. Place the monocular and accessories into the carrying case.

4 WARRANTY INFORMATION

4.1 WARRANTY INFORMATION AND REGISTRATION

4.1.1 WARRANTY INFORMATION

This product is guaranteed to be free from manufacturing defects in material and workmanship under normal use for a period of three (3) years from the date of purchase. In the event that a defect covered by the warranty below occurs during the applicable period stated above, AGM Global Vision, at its discretion, will either repair or replace the product; such action on the part of AGM Global Vision shall be the full extent of AGM Global Vision's liability, and the Customer's sole and exclusive reparation. This warranty does not cover a product if it has been (a) used in ways other than its normal and customary manner; (b) subjected to misuse; (c) subjected to alterations, modifications or repairs by the Customer or by any party other than AGM Global Vision without prior written consent of AGM Global Vision; (d) is the result of a special order or categorized as "close-out" merchandise or merchandise sold "as-is" by either AGM Global Vision or the AGM Global Vision dealer; or (e) merchandise that has been discontinued by the manufacturer and either parts or replacement units are not available due to reasons beyond the control of AGM Global Vision. AGM Global Vision shall not be responsible for any defects or damage that in AGM Global Vision's view are a result from the mishandling, abuse, misuse, improper storage or improper operation of the device, including use in conjunction with equipment that is electrically or mechanically incompatible with, or of inferior quality to, the product, as well as failure to maintain the environmental conditions specified by the manufacturer. This warranty is extended only to the original purchaser. Any breach of this warranty shall be enforced unless the customer notifies AGM Global Vision at the address noted below within the applicable warranty period.

The customer understands and agrees that except for the foregoing warranty, no other warranties written or oral, statutory, expressed or implied, including any implied warranty of merchantability or fitness for a particular purpose, shall apply to the product. All such implied warranties are hereby and expressly disclaimed.

4.1.2 LIMITATION OF LIABILITY

AGM Global Vision will not be liable for any claims, actions, suits, proceedings, costs, expenses, damages, or liabilities arising out of the use of this product. Operation and use of the product are the sole responsibility of the Customer. AGM Global Vision's sole undertaking is limited to providing the products and services outlined herein in accordance with the terms and conditions of this Agreement. The provision of products sold and services performed by AGM Global Vision to the Customer shall not be interpreted, construed, or regarded, either expressly or implied, as being for the benefit of or creating any obligation toward any third party of legal entity outside AGM Global Vision and the Customer; AGM Global Vision's obligations under this Agreement extend solely to the Customer. AGM Global Vision's liability hereunder for damages, regardless of the form or action, shall not exceed the fees or other charges paid to AGM Global Vision by the customer or customer's dealer. AGM Global Vision shall not, in any event, be liable for special, indirect, incidental, or consequential damages, including, but not limited to, lost income, lost revenue, or lost profit, whether such damages were foreseeable or not at the time of purchase, and whether or not such damages arise out of a breach of warranty, a breach of agreement, negligence, strict liability, or any other theory of liability.

4.1.3 PRODUCT REGISTRATION

In order to validate the warranty on your product, the customer must complete and submit AGM Global Vision PRODUCT REGISTRATION FORM on our website (www.agmglobalvision.com/customer-support).

4.1.4 OBTAINING WARRANTY SERVICE

To obtain warranty service on your unit, the End-user (Customer) must notify the AGM Global Vision service department via e-mail. Send any requests to support@agmglobalvision.com to receive a Return Merchandise Authorization number (RMA). When returning any device, please take the product to your retailer, or send the product, postage paid and with a copy of your sales receipt, to AGM Global Vision's service center at the address listed above. All merchandise must be fully insured with the correct postage; AGM Global Vision will not be responsible for improper postage or merchandise that becomes lost or damaged during shipment. When sending product back, please clearly write the RMA# on the outside of the shipping box. Please include a letter that indicates your RMA#, the Customer's Name, a Return Address, reason for the return, contact information (valid telephone numbers and/or an e-mail address), and proof of purchase that will help us to establish the valid start date of the warranty. Product merchandise returns that do not have an RMA# listed may be refused, or a significant delay in processing may occur. Estimated Warranty service time is 10-20 business days. The End-user/Customer is responsible for postage to AGM Global Vision for warranty service. AGM Global Vision will cover return postage/shipping after warranty repair to the End-user/Customer only if the product is covered by the aforementioned warranty. AGM Global Vision will return the product after warranty service by domestic UPS Ground service and/or domestic mail. Should any other requested, required, or international shipping methods be necessary, the postage/shipping fee will be the responsibility of the End-user/Customer.

For service, repair or replacement, please contact:

AGM Global Vision, LLC

2407 E Interstate 30, Suite 100

Grand Prairie, TX 75050

Tel. 928.333.4300

support@agmglobalvision.com

www.agmglobalvision.com

5 SPECIFICATIONS

5.1 SPECIFICATIONS

TABLE 5-1. WOLF-14 SPECIFICATIONS

ITEM	DATA
Image Intensifier	Gen 2+
Optical System	25 mm; F/1.2
Magnification	1x
FOV	42°
Diopter Adjustment	-5D to +5D
Lens Coating	Multilayer broadband coating
Focus Range	0.25 m to infinity
Bright Light Cutoff System	Yes
Flip-up Turn Off Function	Yes
IR Illuminator	Yes
Battery Type	One CR123A (3V) or one AA (1.5V)
Battery Life (Operating)	Up to 40 hr (IR off)
Operating Temperature	-40°C to +50°C (-40°F to +122°F)
Humidity Range	5% - 98%
Environment Rating	IP65 (IP67 optional)
Dimensions (w/o eyecup)	115 × 69 × 54 mm (4.5 × 2.7 × 2.1 in)
Weight (w/o battery)	290 g (0.64 lb)

All data are subject to change without notice.



AGM Global Vision, LLC

MAIN OFFICE

2407 E Interstate 30, Suite 100

Grand Prairie, TX 75050

Tel. 928.333.4300

support@agmglobalvision.com

www.agmglobalvision.com

EUROPEAN OFFICE

#6 Andrey Lyapchev Blvd

Sofia, P.C. 1756

Bulgaria

Tel. +35.988.746.4377

(technical support)

info@agmglobalvision.eu

www.agmglobalvision.eu

AGMglobalvision.com