

NVG-40 NVG-50

NIGHT VISION GOGGLES/BINOCULARS

USER MANUAL

© 2025 AGM Global Vision, LLC. All rights reserved.

This documentation is subject to change without notice.

No parts of this manual, in whole or in part, may be copied, photocopied, translated, or transmitted by any electronic medium or in machine-readable form without the prior written permission of AGM Global Vision, LLC.

Approved for public release, distribution unlimited.

If you have questions that are not covered in this manual, or need service, contact AGM Global Vision customer support for additional information prior to returning a product.

AGM Global Vision, LLC

2407 E Interstate 30, Suite 100

Grand Prairie, TX 75050

Tel. 928.333.4300

support@agmglobalvision.com

www.agmglobalvision.com

EXPORT INFORMATION

Buyer acknowledges that all products supplied by AGM Global Vision, LLC are subject to U.S. export control laws, including, but not limited to, the Export Administration Regulations, the International Traffic in Arms Regulations, the International Economic Emergency Powers Act, and various U.S. embargoes and sanctions. AGM Global Vision products may not be exported, re-exported, or transferred contrary to U.S. export control laws. In particular, AGM Global Vision products may not be exported, re-exported, or transferred to prohibited countries, individuals, organizations, or entities, including but not limited to those individuals and entities listed on the List of Specially Designated Nationals and Blocked Persons administered or maintained by the U.S. Office of Foreign Assets Control ("OFAC"), the various lists maintained by the Bureau of Industry and Security of the Department of Commerce, and the U.S. State Department and Buyer represents and warrants that neither Buyer nor any of its officers, directors, or employees are on such lists. Distribution or resale by Buyer to such countries, individuals, organizations, or entities is expressly prohibited. Buyer has and will maintain a positive process to ensure compliance with this Section.

LIST OF CONTENTS

TITLE	PAGE
Safety Summary	4
SECTION 1. GENERAL INFORMATION	6
1.1 System Description	6
1.2 Key Features	7
1.3 Standard Components	8
1.4 Optional Equipment	9
SECTION 2. OPERATING INSTRUCTIONS	10
2.1 Installation and Mounting	10
2.2 System Controls	11
2.3 Operating Procedures	13
SECTION 3. MAINTENANCE AND TROUBLESHOOTING	22
3.1 Maintenance	22
3.2 Troubleshooting	23
SECTION 4. WARRANTY INFORMATION	25
4.1 Warranty Information and Registration	25
SECTION 5. SPECIFICATIONS	28
5.1 Specifications	28
APPENDIX	30
A. Spare Parts List	30

SAFETY SUMMARY

- Read and follow all instructions
- Read all warnings
- Only use the attachments/accessories specified by the manufacturer
- All service must be provided by the manufacturer

WARNING:

This product contains natural rubber latex, which may cause potentially fatal allergic reactions! If you are allergic to latex, it is important that you strictly avoid exposure to products that contain it.

WARNINGS:

The intensifier's phosphor screen contains toxic materials. Please note:

- If the intensifier tube breaks, be extremely careful to avoid inhaling the phosphor screen material. DO NOT allow the material to come in contact with your mouth, eyes, or any open wounds on the skin.
- If the phosphor screen material comes in contact with your skin, wash it off immediately with soap and water.
- If you inhale or swallow any phosphor screen material, drink a lot of water, induce vomiting, and seek medical attention as soon as possible.

WARNINGS:

- DO NOT DISASSEMBLE THE DEVICE. Disassembly can cause permanent damage.
- Use of the NVG-40/NVG-50 in brightly light conditions and in the places with bright light sources such as firelight, headlights, searchlights, etc. can damage the unit's intensifier tubes. Avoid exposing the unit to these types of light sources.
- When operating the device in extremely dark conditions, the light from the unit's IR illuminator will be invisible to the unaided eye. However, the light can be detected by other night vision devices (NVD).
- To reduce the risk of detection by another NVD, avoid prolonged activation of the IR illuminator.
- The IR light is more easily detected by an NVD when used in smoke, fog and rain. Avoid prolonged activation of the unit's IR illuminator in these conditions.

CAUTIONS:

- The NVG-40/NVG-50 is a precision optical instrument. To prevent damage to the unit, it should always be handled carefully.
- Do not scratch the external lens surfaces or touch them with your fingers.
- To protect the image intensifier, keep the lens cap securely fitted over the objective lens when the device is not in use, or when it is being used in daylight conditions.
- Keep the equipment clean. Protect it from moisture, dramatic temperature drops, and electrical shocks.
- DO NOT force the equipment controls past their stopping points.
- DO NOT leave the equipment activated during breaks in operation.
- DO NOT store the equipment with the batteries installed.
- Thoroughly clean and dry each item before placing them into the storage case.

NOTES:

- Do not test the device in daylight conditions for more than ten (10) minutes, even with the daylight filter/ lens cap on.
- The purpose of the built-in IR illuminator is to provide additional illumination when necessary while viewing scenes at close distances (up to 3 meters).
- The equipment requires some ambient light (moonlight, starlight, etc.) to operate.
- Performance of the device in night-time conditions depends on the level of ambient light in the environment. Please remember the following:
 - The level of ambient light is reduced by the presence of clouds, shade, or objects that block natural light (trees, buildings, etc.).
 - The equipment is less effective when operated in shadows and other darkened areas.
 - The equipment is less effective when operated in rain, fog, sleet, snow, dust or smoke.
 - The equipment will not “see” through dense smoke.

1 GENERAL INFORMATION

1.1 SYSTEM DESCRIPTION

The AGM NVG-40 and NVG-50 are a dual-channel night vision systems. The NVG-40/NVG-50 utilizes the principle of intensification of the residual light that is reflected from the surrounding objects. The optical system of the unit consists of two monocular channels, each consisting of a lens, an image intensifier tube (IIT), and an eyepiece.

This device operates with a single gain control knob for both channels. Each unit allows for vertical adjustment (using the head or helmet mount), fore-and-aft adjustment, objective lens focus, eyepiece focus, and interpupillary distance adjustment. The binoculars are equipped with an infrared (IR) light-emitting diode (or illuminator) to provide additional illumination for reading a map. The binoculars are also equipped a low battery indicator, a bright light cut-off system indicator, and IR illuminator indicator in the field of view of device.

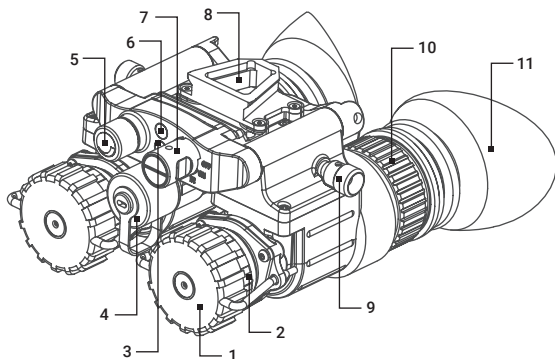

FIGURE 1-1. NVG-40/NVG-50 SYSTEM DESCRIPTION

TABLE 1-1. NVG-40/NVG-50 SYSTEM DESCRIPTION

ITEM	DESCRIPTION	ITEM	DESCRIPTION
1	Lens Cap	7	Turn-Pull Operating Switch
2	Focus Ring	8	Mounting Bracket
3	Photoreceiver	9	Interpupillary Distance Adjustment Knob
4	Battery Cap	10	Diopter Adjustment Ring
5	Gain Control Knob	11	Eyepiece
6	Built-In IR Illuminator		

1.2 KEY FEATURES

- Rotating binocular design allows low profile against helmet when in stowed position and ability to use as a single monocular
- Binocular design for sustained viewing periods and improved depth perception
- Manual system gain and focus adjustments for custom image quality optimization
- Auto OFF when stowed; resumes power when deployed
- Integrated infrared (IR) illuminator
- Head or helmet-mountable
- Low-battery, bright light cut-off, and IR indicators in eyepiece
- Self-contained system operating on a single AA or CR123 battery
- Optional remote battery pack for extended use
- 3-year warranty

1.3 STANDARD COMPONENTS

The standard components of the NVG-40/NVG-50 are shown in Figure 1-2 and listed in Table 1-2.

The ITEM column indicates the number used to identify items in Figure 1-2.

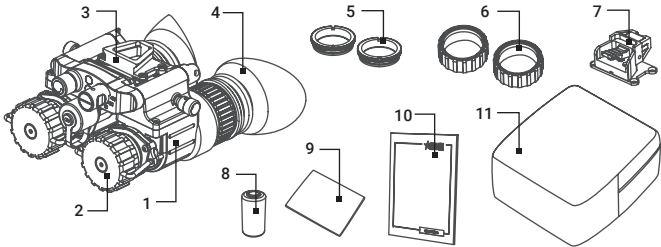

FIGURE 1-2. NVG-40/NVG-50 STANDARD COMPONENTS

TABLE 1-2. NVG-40/NVG-50 STANDARD COMPONENTS

ITEM	DESCRIPTION	QUANTITY
1	Night Vision Binocular	1
2	Lens Cap	1
3	Mounting Bracket (preinstalled NVG Interface Shoe)	1
4	Eyecup	1
5	Demist Shield	2
6	Sacrificial Window	2
7	Bayonet/Horn Interface Shoe	1
8	Battery	1
9	Lens Cloth	1
10	User Manual	1
11	Soft Carrying Case	1

1.4 OPTIONAL EQUIPMENT

The optional equipment of the NVG-40/NVG-50 is shown in Figure 1-3 and listed in Table 1-3.

The ITEM column indicates the number used to identify items in Figure 1-3.

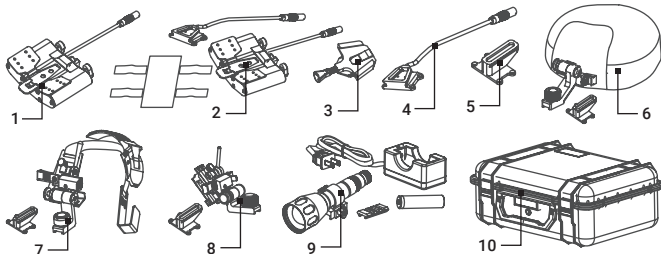

FIGURE 1-3. NVG-40/NVG-50 OPTIONAL EQUIPMENT

TABLE 1-3. NVG-40/NVG-50 OPTIONAL EQUIPMENT

ITEM	DESCRIPTION	PART NO.
1	Battery Pack	6108BPA1
2	Battery Pack Kit G50 (comes included with Battery Pack, NVG Interface Shoe with Connector, Velcro® Battery Case Holder)	6108EBP1
3	Battery Locking Plate Adapter	6108BLP1
4	NVG Interface Shoe with Connector	6108ISC1
5	Mini-Rail Interface Shoe	6506MRN1
6	Goggle Kit W-G50	6104GK51
7	Helmet Mount G50MP for MICH and PASGT Helmets	6103HM51
8	Helmet Mount G50S for Shroud	6103HS51
9	Sioux850-W kit (includes Sioux850 Long-Range Infrared Illuminator, Mount, Adapter, Rechargeable Battery and Charger)	501SIOUW850IR1
10	Hard Case for Storage/Transportation	6610HCS1

2 OPERATING INSTRUCTIONS

2.1. INSTALLATION AND MOUNTING

CAUTION:

To protect the intensifier tube when the sight is not in use or when it is being operated in daylight, keep the protective lens cap securely fitted over the lens.

2.1.1 BATTERY INSTALLATION

The NVG-40/NVG-50 operates on a single CR123A or AA battery. This is possible by repositioning the battery adapter in the battery cap.

Low Battery Indicator

When the binoculars are ON, a flashing red LED indicator in the eyepiece viewing area indicates that the battery is low. This indicator provides an alert the user to replace the battery.

CR123A Battery Installation

1. Unscrew the battery cap (A) and insert (B) the CR123A battery (C), observing the polarity markings (D) on the body of the device.
2. With the battery adapter installed, screw the battery cap back on securely.

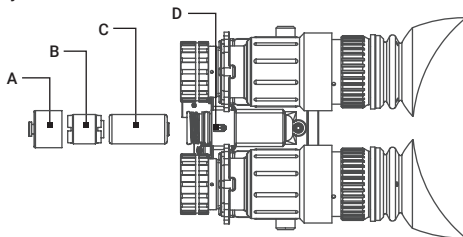

FIGURE 2-1. CR123A BATTERY INSTALLATION

AA Battery Installation

1. Unscrew the battery cap(A).
2. Unscrew the battery adapter (B) from the cap (A), turn it around, and screw in the other end.
3. Insert the AA battery (C), observing the polarity markings (D) as indicated on the body of the device.
4. Screw the battery cap back into place.

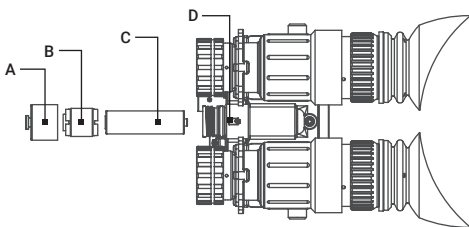

FIGURE 2-2. AA BATTERY INSTALLATION

2.2 SYSTEM CONTROLS

2.2.1 TURN-PULL OPERATING SWITCH

The turn-pull operating switch performs the following functions:

- Activates the NVG-40/NVG-50 when turned to ON.
- To activate built-in IR illuminator, pull switch out and turn to IR position. The IR illuminator will activate on, and red LED indicators in both eyepieces will glow. Rotate the switch to ON position to deactivate the IR.
- Deactivates the NVG-40/NVG-50 when turned to OFF position.

2.2.2 DIOPTER ADJUSTMENT RINGS

The diopter adjustment ring allows a user to alter the viewfinder to accommodate that individual's eyesight for optimum image sharpness. NVG has a separate adjustment for each eyepiece. While looking through the eyepiece, rotate the diopter adjustment ring to optimize the sharpness of the image in the viewfinder.

2.2.3 FOCUS RING

Bring the object into focus by turning the objective focus ring (counter clockwise for far focus, clockwise for near focus, if you look in the eyepieces). Rotate the focus ring until the subject looks sharp in the viewfinder.

2.2.4 INTERPUPILLARY DISTANCE KNOB ADJUSTMENT

Adjusts the distance between each eyepiece by rotating the knobs together or apart, allowing for each eye to observe the entire field at the same time.

2.2.5 GAIN CONTROL KNOB

Used to adjust the gain (brightness) of the viewed image. Turn the gain control to balance the illumination input to the eyes.

2.2.6 INDICATION

When the NVG-40/NVG-50 is ON, the color LED indicators can be shown in the field of view. The color LEDs indicate the following states of the device:

INDICATIONS	COLOR OF LED IN THE FOV
Built-in IR illuminator is activated	Red
Image intensifier tubes are exposed to excessive levels of light	Green
Battery is low	Flashing Red

2.2.7 AUTO POWER OFF FUNCTION

The NVG-40/NVG-50 bright light cut-off feature shuts off power to the binoculars when they are exposed to excessive levels of light for more than 10 seconds.

Automatic shut-off system automatically turns off the device when it is unused (controls are not touched) for 60 minutes. The automatic shut-off function preserves battery life should the device be inadvertently activated.

2.3 PROCEDURES

2.3.1 OPERATING PROCEDURES

1. Verify that the battery is installed as indicated on the unit body.

NOTE:

Only operate the binocular in dark environments. If it necessary to operate the device in daylight, use the objective lens caps to cover the objective lenses. The pinhole at the center of the lens caps allows to check the operation ability of the device in daylight conditions.

2. Remove the lens cap and place it over the housing of the lens.
3. Turn the function switch ON. After a slight delay, a green or white glow will appear in the eyepiece of the unit.
4. Adjust the unit diopter by rotating the ring of the eyepiece.
5. Observe the scene. Rotate the focus ring until the image is clear and sharp.
6. Adjust the brightness of the image using the gain control knob.

MONOCULAR GOGGLES POSITION

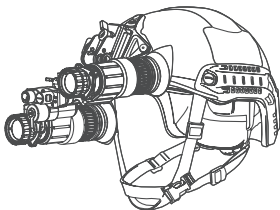

STOWED POSITION

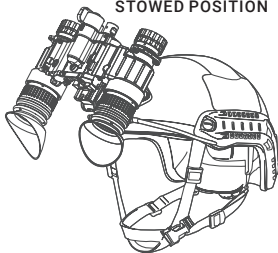

FIGURE 2-3. NVG POSITION

The NVG-40/NVG-50 can be used as one-eye observational unit by choosing which side you want to use as your night vision monocular and rotate the other unit up and out of the way. The power of unit will be switched off in rotated up position and it will be on automatically when returned back to the working position.

NOTE:

If the automatic shut-off system turns off the device, turn the operation switch to OFF position and then back to ON position for continuing operation.

NOTE:

If the bright light cut-off feature turns off the device, the power will turn on automatically when the level of light decreases.

2.3.2 IR ILLUMINATOR OPERATIONS

NOTE:

The built-in IR illuminator is designed to provide additional illumination (when needed) while viewing scenes or targets from a short distance (up to 3m).

To turn built-in IR Illuminator on, pull the operation switch out and turn it from ON to the IR position.

Red LED indicators in field of view of both eyepieces will appear and indicate the IR illuminator is operating.

Rotate the switch to ON position to deactivate the IR.

IR Illuminator will be switched off when both monocular units are rotated to the side and upward. IR Illuminator will be on automatically when one of monoculars returns to the working position.

2.3.3 OPERATING UNDER CHANGING LIGHT CONDITIONS

If the ambient light level exceeds the limit, the NVG-40/NVG-50 automatic protective system will shut off the intensifier tubes. If a mission must be carried out in changing light conditions, the user can shut down the protective system manually by closing the photoreceiver.

NOTE:

DO NOT forget to open the photoreceiver after completing your mission.

2.3.4 INSTALLING A MOUNTING BRACKET TO THE NVG-40/NVG-50

The NVG-40/NVG-50 comes fully-assembled with a dovetail type NVG Interface Shoe. The NVG Interface Shoe is attached to the binoculars body with four flathead socket cap screws.

To replace the NVG Interface Shoe to other optional bracket, please follow the instructions below:

1. Remove the four screws that attach the bracket to the unit body.
2. Remove the bracket.
3. Place a new bracket and affix with four screws.

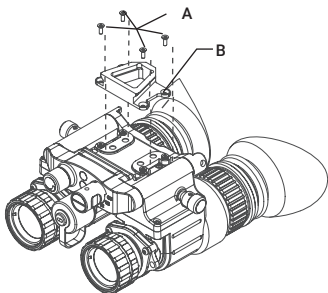

FIGURE 2-4. INSTALLING A MOUNTING BRACKET

2.3.5 MOUNTING THE NVG-40/NVG-50 TO A HELMET/ HEADGEAR ASSEMBLY

For hands-free use of the NVG-40/NVG-50, it can be installed to the AN/PVS-7D, AN/PVS-14, AN/PVS-7A/C, AN/PVS-15, and AN/PVS-18 mounts, or to the mounts with mini-rail interface. With the mount, the NVG can be positioned directly in front of the user's eyes, or flipped out of the field of view.

NVG Interface Shoe (preinstalled) is used for installing the NVG-40/NVG-50 to a either standard dovetail type headset and helmet mount.

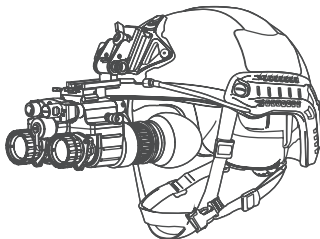

FIGURE 2-5. DOVETAIL TYPE HELMET MOUNT

Bayonet/Horn Interface Shoe is used for installing the NVG-40/NVG-50 to a either standard bayonet/horn type headset and helmet mount.

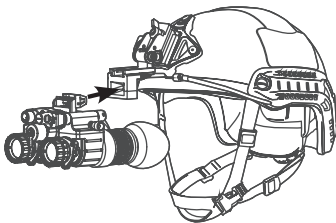

FIGURE 2-6. BAYONET/HORN TYPE HELMET MOUNT

NVG Interface Shoe with Connector is used for installing the NVG-40/ NVG-50 to either standard dovetail type headset and helmet mounts and connecting the Battery Pack.

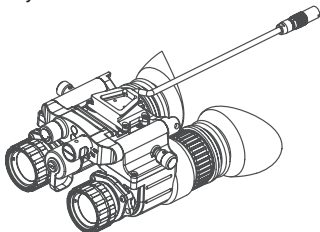

FIGURE 2-7. NVG-40/NVG-50 INTERFACE SHOE WITH CONNECTOR

Adapter (Mini-Rail Interface Shoe) is used for installing the NVG-40/ NVG-50 to the Goggle Kit W-G50, Helmet Mount G50MP and Helmet Mount G50S with mini-rail interface.

NOTE:

The power of NVG-40/NVG-50 will be turned off when the device is swing up using the flip-up mechanism of Goggle Kit W-G50, Helmet Mount G50MP or Helmet Mount G50S. The power will be on automatically when device is returned back to the working position.

Install the necessary bracket to the NVG-40/NVG-50 per instructions in paragraph 2.3.4.

2.3.6 GOGGLE KIT W-G50

Mount the NVG to the Cap Goggle Kit W-G50 as follows (refer to Figure 2-8):

1. Put on the goggle kit. Adjust the goggle kit strap pads until the goggles fit securely around your head. Remove the goggle kit.
2. Loosen the screw (A). While pushing down on the button (B), insert the NVG rail into the guide (C) of the goggle kit bracket. Tighten the screw (A).
3. Put on the goggle kit, now mounted with the NVG.
4. To adjust the equipment for greater comfort, loosen the screw (A) and move the unit along the guide (C). With the button (E) pushed, move the unit along the slide-rail (F) until the desired, most comfortable position is reached.
5. The goggle kit has a flip-up mechanism. Push the button (D) of the goggle kit bracket and lift the unit up until it reaches its top position. The unit will automatically turn off when it reaches this position.
6. Push the same button (D) to lower the unit into the correct viewing position. Turn the unit back on to continue your session.

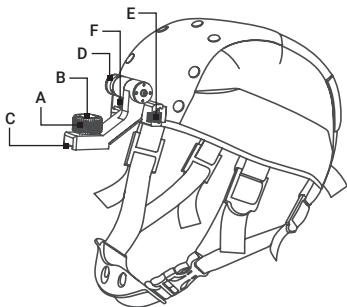

FIGURE 2-8. GOGGLE KIT W-G50

To remove the NVG from the goggle kit, loosen the screw (A), push the button (B), and slide the unit out of the bracket guide (C).

2.3.7 HELMET MOUNT G50MP

An optional flip-up Helmet Mount G50MP can be used to attach the NVG to a helmet. The helmet mount fits the NVG securely onto helmet via a rugged strapping device and grooved hooks. With the helmet mount, the NVG can be positioned directly in front of the user's eyes, or flipped backwards, out of the field of view.

Mount the NVG to a helmet as follows (refer to Figure 2-9):

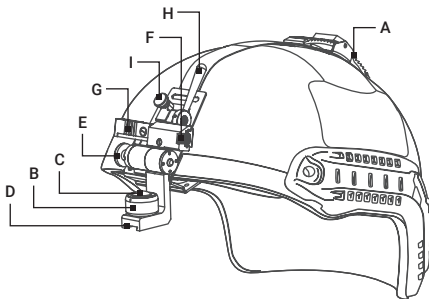

FIGURE 2-9. HELMET MOUNT G50MP

1. Attach the mount to the helmet.
2. Adjust and tighten the strap (A).
3. Loosen the screw (B). With the button (C) pushed down, insert the NVG rail into the guide (D) of the helmet mount bracket. Tighten the screw (B).
4. Put on the helmet with the NVG attached.
5. Push the button (F) and move the unit along the slide-rail (G) until the most comfortable position is reached.
6. Adjust the mount for comfortable using. Loosen the screw (B) and move the unit along the guide (D) for eye relief adjustment. Turn the lever (H) and move the unit along vertical slide-rail until the most comfortable vertical position is reached. Push the button (F) and move the unit along the slide-rail (G) until the most comfortable position is reached.

7. To remove the NVG and turn it around, push the button down (E) and lift the unit up until it reaches the top position. Once it reaches this position, the unit will turn off automatically.
8. Push the same button (E) to lower the NVG into the proper viewing position. Turn the unit on to proceed with your mission.

To remove the NVG from the helmet mount, loosen the screw (B), push down on the button (C), and slide the unit out of the guide (D). To remove the flip-up mechanism from the helmet mount, loosen the lever (H), pull the knob out (I), and slide the flip-up mechanism out of the vertical rail.

2.3.8 HELMET MOUNT G50S FOR SHROUD

An optional Helmet Mount G50S can be used to attach the NVG to a helmet with a shroud. With the helmet mount, the NVG can be positioned directly in front of the user's eyes, or flipped backwards, out of the field of view.

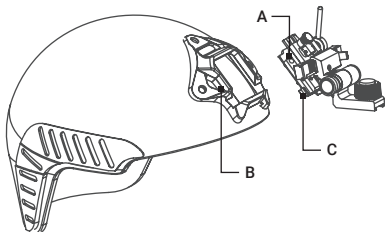

FIGURE 2-10. HELMET MOUNT G50S FOR SHROUD

Mount the NVG to a helmet as follows (refer to Figure 2-10):

1. Attach the mount (A) to the shroud (B). Place the tab at the top of the mount into the notch at the top of the shroud. Press down on the bottom of the mount and snap it into the shroud.
2. Attache the NVG. Adjust position of the unit similar per instructions in paragraph 2.3.7.
3. To remove the Helmet Mount G50S from the shroud, push the button (C).

2.3.9 USING A BATTERY PACK

The NVG-40/NVG-50 with installed NVG Interface Shoe with Connector(A) can be used in conjunction with the Battery Pack for longer run times. When the Battery Pack is connected, it works in conjunction with an internal power source.

When NVG-40/NVG-50 is used as goggle system, the Battery Pack (D) can be installed with Battery Pack Bracket(E) or Velcro® Battery Case Holder on the back side of the helmet.

The Battery Pack connects to the NVG Interface Shoe using the Lemo connector(C) on the cable(B).

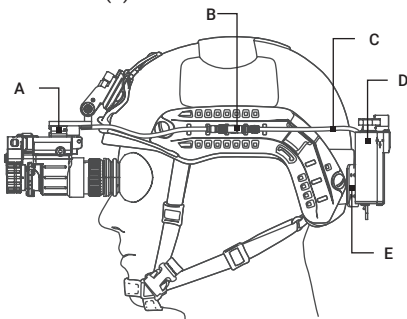

FIGURE 2-11. USING A BATTERY PACK

When NVG-40/NVG-50 is used as handheld NV binoculars, the Battery Pack(A) can be installed with the Battery Locking Plate Adapter directly to the NVG Interface Shoe with Connector(B).

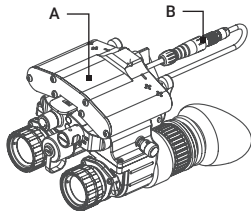

FIGURE 2-12. USING AS HANDHELD NV BINOCULARS

2.3.10 DEMIST SHIELD INSTALLATION

Mount a Demist Shield to the NVG-40/NVG-50 as follows:

1. Remove the eyecup from the NVG-40/NVG-50 eyepiece.
2. Coat the Demist Shield with an anti-fogging compound, to prevent moisture condensation on the surface of the shield.
3. Screw the Demist Shield into the threading of the eyepiece.
4. Secure the eyecup back into place.

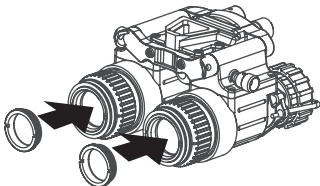

FIGURE 2-13. DEMIST SHIELD INSTALLATION

2.3.11 SACRIFICIAL WINDOW INSTALLATION

Mount a Sacrificial Window to the NVG-40/NVG-50 as follows:

1. Remove the NVG-40/NVG-50 lens cap, if it is in place.
2. Carefully push the Sacrificial Window onto the end of the objective lens of NVG-40/NVG-50 until it stops.

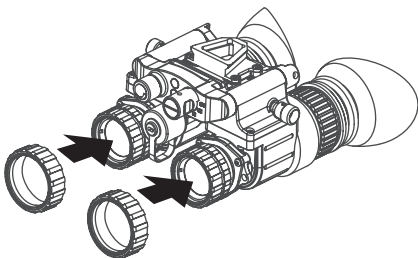

FIGURE 2-14. SACRIFICIAL WINDOW INSTALLATION

3 MAINTENANCE AND TROUBLESHOOTING

3.1 MAINTENANCE

3.1.1 BATTERY REMOVAL AND REPLACEMENT

Refer to Part 2.1 for battery installation procedures.

3.1.2 CLEANING THE NVG-40/NVG-50

Wipe the housing with a damp cloth as needed.

CAUTION:

Do not use abrasives or solvents to clean the housing, lens, or display window. Do not use ammonia-based cleaning products to clean the lens. Doing so may damage the anti-reflective coating of the lens

The NVG-40/NVG-50 lens is designed for the harsh outdoor environment and has a coating for durability and anti-reflection, but it may require cleaning occasionally. Avoid scratching the lens and/or leaving fingerprints on the optics. Optics can be damaged by improper cleaning. Clean the lens according to the instructions below when image quality degradation is noticed or excessive dirt or other contaminant is on the lens.

Do not use abrasive materials, such as paper or scrub brushes as this will possibly damage the lens by scratching it. Only wipe the lens clean when there is visible contamination on the surface.

PREFERRED METHOD FOR CLEANING THE LENS

Materials:

- Optical-grade cloth
- Pure water (de-ionized or other)
- Isopropyl alcohol (IPA)

Saturate a piece of the lens tissue with the water and drape it over the lens. Let the surface tension of the water pull the tissue onto the lens surface and then drag the tissue across the lens surface. Repeat several times with different pieces of tissue.

Repeat the same step using IPA instead of water. Drag the final piece of tissue over the lens several times to prevent pooling, which could leave a residue behind.

3.2 TROUBLESHOOTING

Table 3-1 common malfunctions that may occur with your equipment. Perform the tests, inspections, and corrective actions in the order listed. This table does not list all the malfunctions that may occur with your device, nor does it include all tests, inspections, or corrective actions that may be necessary to correct them. If you identify an equipment malfunction that is not listed, or the suggested corrective actions do not correct the issue, please contact Customer Support.

TABLE 3-1. OPERATOR TROUBLESHOOTING

MALFUNCTION	PROBABLE CAUSE/ TEST/INSPECTION	CORRECTIVE ACTION
1. Binocular fails to activate.	Visual. Check for defective, missing, or improperly installed battery	Turn the power switch to OFF position, and then turn it ON. Replace the battery or install it correctly.
2. IR source fails to activate.	In a dark location with system turned on, activate IR source. Visually check IR source operation; scene should brighten.	If the IR source still fails to activate, please contact Customer Support.
3. IR source indicator fails to activate.	Visual.	Please contact Customer Support.

MALFUNCTION	PROBABLE CAUSE/ TEST/INSPECTION	CORRECTIVE ACTION
4. Poor image quality.	Check objective lenses or eyepiece lenses focus. Check for fogging or dirt on the objective and eyepiece lenses.	Refocus. Clean lens surfaces per Paragraph 4.4.1.
5. Light visible around eyecup.	Check eye relief distance. Check eyecups for resiliency.	Adjust for proper eye relief distance. If eyecup is defective, please contact Customer Support.
6. Diopter adjustment cannot be made.	Check to see if the diopter adjustment is bent or broken.	If damaged, please contact Customer Support.
7. Battery cap is difficult to open.	Verify that the O-ring is present. Check for damage to the battery cap.	If the O-ring is missing, please contact Customer Support. If damaged, please contact Customer Support.
8. Binocular does not shut off when exposed to bright light.	Visual. Perform the following test in daylight or bright room light (not fluorescent light). Place the cap over the objective lens. Turn the binocular ON and observe that it cuts off within 30-70 seconds after powered on. Turn the binocular OFF and then ON to power up the monocular.	If damaged, please contact Customer Support.

4 WARRANTY INFORMATION

4.1 WARRANTY INFORMATION AND REGISTRATION

4.1.1 WARRANTY INFORMATION

This product is guaranteed to be free from manufacturing defects in material and workmanship under normal use for a period of three (3) years from the date of purchase. In the event that a defect covered by the warranty below occurs during the applicable period stated above, AGM Global Vision, at its discretion, will either repair or replace the product; such action on the part of AGM Global Vision shall be the full extent of AGM Global Vision's liability, and the Customer's sole and exclusive repairation. This warranty does not cover a product if it has been (a) used in ways other than its normal and customary manner; (b) subjected to misuse; (c) subjected to alterations, modifications or repairs by the Customer or by any party other than AGM Global Vision without prior written consent of AGM Global Vision; (d) is the result of a special order or categorized as "close-out" merchandise or merchandise sold "as-is" by either AGM Global Vision or the AGM Global Vision dealer; or (e) merchandise that has been discontinued by the manufacturer and either parts or replacement units are not available due to reasons beyond the control of AGM Global Vision. AGM Global Vision shall not be responsible for any defects or damage that in AGM Global Vision's view are a result from the mishandling, abuse, misuse, improper storage or improper operation of the device, including use in conjunction with equipment that is electrically or mechanically incompatible with, or of inferior quality to, the product, as well as failure to maintain the environmental conditions specified by the manufacturer. This warranty is extended only to the original purchaser. Any breach of this warranty shall be enforced unless the customer notifies AGM Global Vision at the address noted below within the applicable warranty period. The customer understands and agrees that except for the foregoing warranty, no other warranties written or oral, statutory, expressed or

implied, including any implied warranty of merchantability or fitness for a particular purpose, shall apply to the product. All such implied warranties are hereby and expressly disclaimed.

4.1.2 LIMITATION OF LIABILITY

AGM Global Vision will not be liable for any claims, actions, suits, proceedings, costs, expenses, damages, or liabilities arising out of the use of this product. Operation and use of the product are the sole responsibility of the Customer. AGM Global Vision's sole undertaking is limited to providing the products and services outlined herein in accordance with the terms and conditions of this Agreement. The provision of products sold and services performed by AGM Global Vision to the Customer shall not be interpreted, construed, or regarded, either expressly or implied, as being for the benefit of or creating any obligation toward any third party of legal entity outside AGM Global Vision and the Customer; AGM Global Vision's obligations under this Agreement extend solely to the Customer. AGM Global Vision's liability hereunder for damages, regardless of the form or action, shall not exceed the fees or other charges paid to AGM Global Vision by the customer or customer's dealer. AGM Global Vision shall not, in any event, be liable for special, indirect, incidental, or consequential damages, including, but not limited to, lost income, lost revenue, or lost profit, whether such damages were foreseeable or not at the time of purchase, and whether or not such damages arise out of a breach of warranty, a breach of agreement, negligence, strict liability, or any other theory of liability.

4.1.3 PRODUCT REGISTRATION

In order to validate the warranty on your product, the customer must complete and submit AGM Global Vision PRODUCT REGISTRATION FORM on our website (www.agmglobalvision.com/customer-support).

4.1.4 OBTAINING WARRANTY SERVICE

To obtain warranty service on your unit, the End-user (Customer) must notify the AGM Global Vision service department via e-mail. Send any requests to support@agmglobalvision.com to receive a Return Merchandise Authorization number (RMA). When returning any device, please take the product to your retailer, or send the product, postage paid and with a copy of your sales receipt, to AGM Global Vision's service center at the address listed above. All merchandise must be fully insured with the correct postage; AGM Global Vision will not be responsible for

improper postage or merchandise that becomes lost or damaged during shipment. When sending product back, please clearly write the RMA# on the outside of the shipping box. Please include a letter that indicates your RMA#, the Customer's Name, a Return Address, reason for the return, contact information (valid telephone numbers and/or an e-mail address), and proof of purchase that will help us to establish the valid start date of the warranty. Product merchandise returns that do not have an RMA# listed may be refused, or a significant delay in processing may occur. Estimated Warranty service time is 10-20 business days. The End-user/Customer is responsible for postage to AGM Global Vision for warranty service. AGM Global Vision will cover return postage/shipping after warranty repair to the End-user/Customer only if the product is covered by the aforementioned warranty. AGM Global Vision will return the product after warranty service by domestic UPS Ground service and/or domestic mail. Should any other requested, required, or international shipping methods be necessary, the postage/shipping fee will be the responsibility of the End-user/Customer.

For service, repair or replacement, please contact:

AGM Global Vision, LLC

2407 E Interstate 30, Suite 100

Grand Prairie, TX 75050

Tel. 928.333.4300

support@agmglobalvision.com

www.agmglobalvision.com

5 SPECIFICATIONS

5.1 SPECIFICATIONS

TABLE 5-1. NVG-40/NVG-50 SPECIFICATIONS

	NVG-50	NVG-40
Optical Specifications		
Magnification	1×	
Lens System	19 mm; F/1.26	27 mm; F/1.3
FOV	51°	40°
Focus Range	0.25 m to infinity	
Diopter Adjustment	-6 to +2 dpt	
Eye Relief	17 mm	25 mm
User Interface		
Operation Switch	Power On/ Off; IR Illuminator On/Off	
Gain Control Knob	Adjusts the image brightness	
Diopter Adjustment Rings	Adjusts the eyepiece diopter	
Focus Rings	Adjusts the objective lens focus	
LED Indicators	Low Battery, IR On, and Excessive Light Conditions	
System Specifications		
Manual Gain Control	Yes	
Bright Light Cut-Off	Yes	
Automatic Shut-Off System	Yes	
Infrared Illuminator	Yes	

	NVG-50	NVG-40
Power		
Battery Type	One AA 1.5V battery or one CR123A Lithium 3V battery / Optional Battery Pack	
Battery Life (Operating)	Up to 20 hrs; up to 80 hrs with optional Battery Pack	
Environmental		
Operating Temperature	-40°C to +50°C (-40°F to +122°F)	
Storage Temperature	-50°C to +50°C (-58°F to +122°F)	
Physical		
Interpupillary Distance	54 to 78 mm	
Dimensions	115 × 118 × 73 mm (4.5 × 4.6 × 2.8 in)	113 × 118 × 73 mm (4.4 × 4.6 × 2.8 in)
Weight	615 g (1.35 lb)	645 g (1.42 lb)

All data are subject to change without notice.

APPENDIX

A. SPARE PARTS LIST

The parts authorized in this list of spare parts are required for operator maintenance. This list includes parts that must be removed in order to replace authorized parts.

The PART NO. Column indicates the primary number used by the manufacturer to identify an item; this number controls the design and characteristics of the item, including standards, engineering specifications, and inspection requirements.

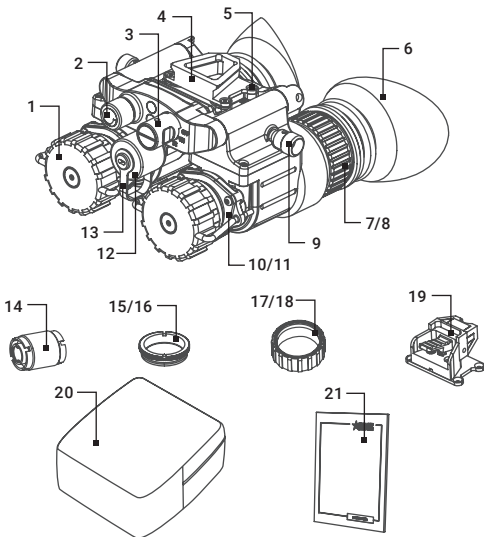

FIGURE A-1. SPARE PARTS

TABLE A-1. SPARE PARTS LIST

ITEM	DESCRIPTION	PART NO.
1	Lens Cap	NVGLCP
2	Gain Control Knob	NVGGCK
3	Operating Switch	NVGOPSW
4	NVG Interface Shoe	NVGINSH
5	Bracket Fixing Screws	NVGBFSC
6	Eyecup	NVGEYCP
7	NVG-50 Eyepiece Assembly	NVG50EYAS
8	NVG-40 Eyepiece Assembly	NVG40EYAS
9	Interpupillary Distance Adjustment Knob	NVGIDAK
10	NVG-50 Objective Lens Assembly	NVG50OBLAS
11	NVG-40 Objective Lens Assembly	NVG40OBLAS
12	Battery Cap	NVGBTCP
13	Battery Cap Retainer	NVGBCRT
14	Battery Adapter	NVGBTAD
15	Demist Shield for NVG-50	NVG50DS
16	Demist Shield for NVG-40	NVG40DS
17	Sacrificial Window for NVG-50	NVG50SWN
18	Sacrificial Window for NVG-40	NVG40SWN
19	Bayonet/Horn Interface Shoe	NVGBHIS
20	Soft Carrying Case	NVGSCCS
21	User Manual	NVGUSMN



AGM Global Vision, LLC

MAIN OFFICE

2407 E Interstate 30, Suite 100

Grand Prairie, TX 75050

Tel. 928.333.4300

support@agmglobalvision.com

www.agmglobalvision.com

EUROPEAN OFFICE

#6 Andrey Lyapchev Blvd

Sofia, P.C. 1756

Bulgaria

Tel. +35.988.560.0326

info@agmglobalvision.eu

www.agmglobalvision.eu